



ELECTRONICS CORPORATION OF INDIA LIMITED
A Govt. of India (Dept. of Atomic Energy) Enterprise
ECIL (Post), Hyderabad – 500062, Telangana, India

DEFENCE SYSTEMS GROUP

REQUEST FOR QUOTATION

Tender No: RFSD 16-094886

Details of RFQ

Scope of Supply	:	Supply of Test Control Equipment (TCE) in Ku Band Frequency	
Type of Tender	:	E-Tender	
Method of Tender	:	Two Part Bid	
Important Dates:		Date	Time
Tender Publishing Date	:	30.08.2025	11:00 Hrs
Tender Document Download Start Date	:	30.08.2025	11:00 Hrs
Last Date of Receiving Queries	:	09.09.2025	17:00 Hrs
Pre-Bid Meeting Date	:	11.09.2025	11:00 Hrs
Replies to Queries by	:	16.09.2025	17:00 Hrs
Due Date for Submission	:	20.09.2025	15:00 Hrs
Opening of Techno-Commercial Bids	:	20.09.2025	15:30 Hrs
Opening of Price Bids	:	Will be informed later	
Contact Person Details	:	In-Charge MMD, CNSG Group, Electronics Corporation of India Limited ECIL (P.O), Hyderabad – 500 062 Tel Nos.040-27182725,27182392 E Mail ID: cndmmd@ecil.co.in	



ELECTRONICS CORPORATION OF INDIA LIMITED
A Govt. of India (Dept. of Atomic Energy) Enterprise
ECIL (Post), Hyderabad – 500062, Telangana, India

Telephone:	040-27182725/2392	In-Charge MMD, CNSG Group, Electronics Corporation of India Limited ECIL (P.O), Hyderabad – 500 062 Telangana, India.
Mobile:	9440808020	
e-Mail:	cndmmd@ecil.co.in	
Fax:	040-27121606	

Tender No: ECIL/PUR/16-094886

Date:30.08.2025

Dear Sir,

Invitation of Bids for Supply of Test Control Equipment:

1. Electronics Corporation of India Ltd., (ECIL) a Government of India undertaking with its registered office at ECIL P.O, Hyderabad – 500062, invites Bids through e-Procurement portal (<https://etenders.ecil.co.in>) for supply of items listed in PART-II of this RFQ. This RFQ is being issued on TwoPartBid basis. The firm has to upload both Techno-Commercial Bid and Price Bid separately in online tender.

2. The address and contact numbers for sending documents or seeking clarifications regarding this RFQ are given below.

a)	Contact details	:	For Technical clarifications: Name: G. Susila, DGM / JalajaGattu, SM RFS Division, Defence Systems Group, ECIL Tel No. 040-27182865 Email: susela_gg@ecil.co.in , jalajagattu@ecil.co.in
			For other RFQ related clarifications: In-Charge MMD, CNSG, ECIL Tel Nos. 040-27182725/2392 Email: cndmmd@ecil.co.in
			For e-Procurement portal related clarifications: Helpdesk No.: 040-27186294/6652/2273 Email: etendering@ecil.co.in

3. This RFQ is divided into five Parts as follows:

Sl. No.	Sections	Document Description	Page No.
(a)	Part I	General Information and Instructions for the Bidders	4-8

(b)	Part II	Essential Details of The Procurement Items.	9-12
(c)	Part III	Standard Terms and Conditions	13-25
(d)	Part IV	Special Terms & Conditions	26-33
(e)	Part V	Price Bid Format.	34-35
(f)	Annexure – A	Technical Specifications	36-43
(g)	Annexure – B	Bid Security Declaration Form	44
(h)	Annexure – C	Pre-Bid Query Format.	45
(i)	Annexure – D	Eligibility Declarations	46-48
(j)	Annexure – E	Performance Bank Guarantee Format.	49-51
(k)	Annexure – F	Restrictions under Rule 144(xi) of GFR 2017	52-54

1. This RFQ is being issued with no financial commitment and ECIL as a Buyer reserves the right to change or vary any part thereof at any stage. Buyer also reserves the right to withdraw the RFQ, should it become necessary at any stage without assigning any reason, whatsoever. ECIL shall have no liability for above mentioned actions.

Thanking you,

Yours faithfully,

For Electronics Corporation of India Limited

Encl: Annexure A to F

Part I – General information and Instructions for the Bidders

Particulars	Sl. No.	Terms and Conditions	Compliance Required	(Yes/No) with Deviation if any
Due Date& Time	1	<u>Last Date and Time for Uploading the Bids: (on 20.09.2025 by 15:00)</u> Bids should be submitted within time & due date through e-procurement portal of ECIL for Supply of items mentioned in Part II of RFQ.	Noted	
Manner of Submitting the Bids:	2	The bidder is required to submit soft copies of their bids electronically on ECIL e-Procurement Portal, using valid Digital Signature Certificates. For necessary instructions please refer to the “User Manual for Vendor” and “User Manual of Bid Preparation” documents available in the Learning Center link on e-Procurement portal. Bids sent by post, fax, mail or e-mail will not be considered.	Complied	
Method of Tender	3	<u>Two Part-Bid System</u> Bidder should submit Techno-commercial & price bids separately. Only the Techno-commercial bid would be opened on the date of bid opening. Price bid will be opened, only when Techno-commercial bids are found to be qualified. Any reference to price in TECHNO-COMMERCIAL BID will render the bid invalid and such bid shall be rejected summarily.	Complied	
Opening of Bids	4	<u>Time and Date for Opening of Bids: (on 20.09.2025 at 15:30)</u> If due to any exigency, the bids are not opened on the date and time mentioned above, the bids will be opened on the next working day.	Noted	
Validity of Bids:	5	The Bids should remain valid till 120 days from the date of submission of bid.	Agreed	
Bid Security Declaration:	6	In place of a Bid Security, every bidder has to sign a bid security declaration form accepting that if they withdraw or modify their bids	Complied	

		during the period of validity, or if they are awarded the contract and they felt to sign the contract, or to submit a performance security (if required) before the deadline defined in the tender document, they will be suspended for the period of one year as specified in the Bid Security Declaration Form, from being eligible to submit bids for contracts with the entity that invited the bids. Every Bidder is required to submit the Bid Security Declaration Form as per Annexure B .		
Earnest Money Deposit (EMD)	7	Techno-Commercial Bid shall accompany interest-free EMD for Rs.1,00,000/- (Rupees One Lakh Only) in the form of Online/ RTGS/ NEFT/IMPS/Demand-Draft/Bank Guarantee drawn on any scheduled bank(i.e., the Second Schedule of RBI Act, 1934) in favour of 'Electronics Corporation of India Limited' and payable at Hyderabad. No EMD shall be accepted in the form of Cheque. EMD is normally to remain valid for a period of 45 days beyond the final bid validity period.	Agreed	
EMD : Mode of payment	8.1	Bidder has to select the appropriate payment option to pay the EMD as applicable and enter details of the instrument.EMD may be furnished in the form of Insurance Surety Bands, Account Payee Demand Draft, Fixed Deposit Receipt from a Commercial Bank, Bank Guarantee (including e-Bank Guarantee) from a Commercial Bank or online payment in an acceptable form safeguarding the purchase's interest in all respects.	Agreed	
	8.2	Bidder should prepare the EMD as per the instructions specified in the tender document. The original instruments should reach ECIL Hyderabad latest by due date and time of bid submission. The details of the DD/any other accepted instrument, physically sent, should tally with the details available in the scanned copy and the data entered during bid submission time on above portal and in case of submission of EMD through online transfer the relevant details should be provided along with the bid to enable linking of the EMD with the tender. Otherwise the	Agreed	

		uploaded bid will be rejected.		
	8.3	EMD, whether in the form of Demand Draft or Bank Guarantee, should be put in a separate sealed cover, super scribed as “EMD” indicating RFQ No. & Date.	Agreed	
	8.4	Techno commercial bid will not be opened if EMD is not submitted in the manner specified herein. Please furnish details of EMD submitted in Bidder’s response column. The details of EMD Submitted to be furnished clearly.	Agreed	
	8.5	EMD will be refunded to the un-successful Bidder after the expiry of the final bid validity but not later than 30 days after the award of the contract and receipt of acknowledgement of P.O. issued to the bidder. EMD will be refunded to successful Bidder upon furnishing PBG (if any). As part of Techno Commercial Bid, Bidder should furnish name of the Bank, Branch, Type of Account and Account No. for refund of EMD.	Agreed	
	8.6	Offers without EMD will not be Considered and will be Summarily rejected.	Agreed	
	8.7	Bank Details of ECIL are as follows: SBI, Banjara Hills BR Hyderabad Cash Credit A/s: 10187982942 IFSC Code: SBIN0013039	Noted	
Forfeiture of EMD:	9	If the Bidder revokes, withdraws and modifies the Bid with in the validity period of the Bid, EMD will be forfeited. In case after issue of PO, Bidder does not acknowledge PO/Supply materials and if PBG is not furnished, EMD will be forfeited.	Agreed	
Exemption of EMD to MSME and Start-	10.1	MSEs registered under Udyam Registration are eligible for availing benefits under the Public Procurement Policy.	Agreed	

Ups	10.2	The registration certificate issued from MSME/NSIC/DIC/KVIC etc. must be valid as on Bid closing date of the tender. Bidder shall ensure validity of registration certificate in case bid closing date is extended.	Agreed	
	10.3	MSEs participating in the tender must submit valid Copy of Udyam Registration Certificate to claim for the exemption of EMD.	Agreed	
	10.4	The MSE Bidders to note and ensure that nature of services and goods/items manufactured mentioned in MSE's certificate matches with the nature of the services and goods /items to be supplied as per Tender.	Agreed	
	10.5	Traders/sole agent/distributors/works contract will not be considered for availing benefits under PP Policy for MSEs Order, 2012 as per Office Memorandum F.No.1(3)/2018-MA, Part-III, dated 25th March, 2022 and any amendments thereafter.	Agreed	
Clarification regarding contents of the RFQ:	11	Bidder requiring clarification regarding the contents of the RFQ shall notify to the Buyer in writing about the clarifications sought not later than the date mentioned in the RFQ for clarifications. Clarification by the purchaser will be sent by e mail or by Speed Post	Agreed	
Modification and Withdrawal of Bids:	12	Bidder may modify or withdraw his bid after submission prior to due date and time prescribed for submission of bids. In case of modification / revision, the latest submitted bid will be treated as valid bid. Bids cannot be modified after the due date for submission of bids. No bids will be accepted after the Due Date and Time.	Agreed	
Clarification regarding details/contents of the Bids:	13	The Buyer may, at his discretion, ask the bidder for clarification of their submitted bid in writing. Change in prices or substance of the bid will not be sought, offered or permitted. The clarifications will be displayed on the website for the benefit of the bidders who are downloading the tender in case of public tender.	Agreed	
Pre-Bid Meeting:	14.1	Before submission of bids, for the bidder to understand clearly all tender requirements, a pre-bid meeting will be held on 11.09.2025 at 11:00Hrs at	Noted	

		ECIL or through virtual meeting (WebEx Link Details will be shared through mail).		
	14.2	The bidder is required to furnish in writing queries, if any (both technical and commercial) on or before 09.09.2025 at 17:00 Hrs as per the prescribed format at Annexure C . A soft copy of the queries should be sent by e-mail.	Noted	
	14.3	Buyer response to the Pre-bid queries and corrigendum, if necessary, will be uploaded on the ECIL e-Procurement Portal/ sent by email.	Noted	
	14.4	No post-bid clarification from the bidder will be entertained.	Noted	
Amendments to RFQ:	15	The buyer reserves the right to issue any amendments, corrigendum, clarification, etc. to the RFQ, giving reasonable time to the Bidder, prior to the due date and time for online bid submission. Bidders are requested to update themselves on ECIL e-Procurement portal the details such as pre-bid clarifications, corrigenda and other documents forming a part of subject RFQ, before submission of their bid	Agreed	
Rejection of Bids:	16	Canvassing by the Bidder in any form, unsolicited letter and post-tender correction may invoke summary rejection of the Bid. Any non-conformity with the techno commercial clauses and technical specifications mentioned in the RFQ will lead to Rejection of Bids	Agreed	

Part II Essential Details of The Procurement Items:

This part of the RFQ Contains the Essential Details pertaining to Procurement of Items.

Particulars	Sl. No	Terms and Conditions	Compliance required	(Yes/No) with Deviation if any		
Schedule of Requirements (SOR)	1	a) Schedule of Requirement as per Technical specifications attached in Annexure –A	Complied			
		<table border="1"> <thead> <tr> <th>S. No.</th> <th>Item Description</th> <th>Qty</th> </tr> </thead> <tbody> <tr> <td>1</td> <td>Supply of Test Control equipment as per Technical specification & Scope of work in Annexure-A</td> <td>As per List of deliverables in Annexure-A</td> </tr> </tbody> </table>			S. No.	Item Description
S. No.	Item Description	Qty				
1	Supply of Test Control equipment as per Technical specification & Scope of work in Annexure-A	As per List of deliverables in Annexure-A				
Delivery Period	2	The ordered quantity to be supplied within 06 Months from the date of receipt of LOI/PO Copy.	Complied			
Mode of Delivery	3	The items are to be delivered strictly as per scheduled delivery date as mentioned in PO, at STORES, CNSG, ECIL HYDERABAD on FOR basis.	Complied			
Consignee Details	4	The items are to be dispatched to: In-charge Stores, MMD, Communication Systems Group, Electronics Corporation of India Limited, ECIL Post Office, Hyderabad, Telangana, India, PIN: 500062 Telephone: 040-27186575 Email: cnsghostores@ecil.co.in	Complied			

Evaluation Criteria	5.1	Bid fulfilling all the eligibility and qualifying requirements of the RFQ, both technically and commercially, will be evaluated.	Noted	
	5.2	In respect of Two-Part Bid system, the techno-commercial bids submitted by the Bidders will be evaluated by the Buyer with reference to the technical characteristics of the items as mentioned in the RFQ along with terms and conditions. The compliance of techno-commercial bids would be determined on the basis of the parameters specified in the RFQ. The Price Bids of only those Bidders will be opened whose Techno-commercial Bids would clear the techno-commercial evaluation.	Noted	
	5.3	The Bidder must quote as per the Price Bid Format given in the portal, without which the Bid will be summarily rejected.	Noted	
	5.4	Total value wise cost will be considered for placement of Purchase Order.	Noted	
Eligibility and Pre-Qualification Criteria:	6	(a) Bidder should be either OEM or Dealer/Distributor/Channel Partner of the OEM.	Complied	
		(b) The Bidder can be Proprietorship/Partnership Firm/Limited Liability Partnership/Private Limited/Limited Company /Society registered under Society's Act/Statutory Bodies etc., and should be operational from last 3 years as on 31.03.2025. Bidder should submit certificate of registration/incorporation/ partnership deed/memorandum and Articles of association/ GST registration/PAN /any other equivalent document showing date and place of incorporation as applicable.	Complied	
		(c) The bid(s) will not be entertained if the same distributor/dealer is representing more than one OEM for a particular item. In case of simultaneous bids, simultaneous bids from OEM directly and also through Channel Partner / Dealers / Distributors the quotes from other than OEMs will be rejected.	Complied	
		(d) Bidders should have well established office set up and registration with Tax Department and shall provide required Certificate of Registration	Complied	

	wherever applicable, viz., PAN No, GSTN etc. OEMs/ Agents should have presence in India from last three years preceding the month of March 2025. ECIL may visit the bidders office during techno commercial evaluation.		
	(e) The bids from the supplier / suppliers who have earlier supplied similar material to ECIL, and the PO /Contract was short closed or cancelled due to non-compliance to the technical specifications will not be considered for this tender, as the requirement is meant for a Nation important Project.	Complied	
	(f) The Bidder Firm/ Company should not have been blacklisted, debarred or prosecuted by any Central Government or State Government Department/ Government Organization/ PSU for corrupt, fraudulent or any other unethical business practices. Bidder shall not have any litigation pending with any of the Govt. organizations.	Complied	
	(g) The Bidder Firm / company should have average turnover of Rs.40Lakhs for last three audited years ending 31 st March 2025 Audited balance sheets, IT Returns and P&L account for these financial years should be furnished. OR Bidder can submit turn over certificate from Chartered Accountant.	Complied	
	(h) The vendor should have delivered a similar system to any Govt organization like DRDO or PSU and purchase order copies to be enclosed with the techno-commercial bid.	Complied	
	(i) Accordingly vendor should arrange a demonstration of the same to the TEC committee during TEC for any frequency Band (X/Ku/Ka) covering Range, Doppler for moving target, Range resolution, Maximum RF output power irrespective of RF input power, swerling RCS models.	Complied	
	(j)The net worth of the Bidder firm (manufacturer or principal of authorized representative/Dealer) should not be negative on 31.03.2025 and also should	Complied	

	<p>have not eroded by more than 29.73 lakhs in the last three years, ending on 31.03.2025.</p> <p>(j) Bidder should have positive net worth as per latest audited financial results. A Certificate duly certified by a registered Chartered Accountant to be submitted</p>		
	<p>(k) Bidder should not be insolvent, in receivership, bankrupt or being wound up, not have its affairs administered by a court or a judicial officer, not have its business activities suspended and must not be the subject of legal proceedings for any of these reasons.</p>	Complied	

Part III – STANDARD TERMS AND CONDITIONS

The Bidder is required to give mandatory confirmation of their acceptance of the Standard Conditions of the RFQ mentioned below, which will automatically be considered as part of the contract concluded with the Successful Bidder. Failure to do so may result in rejection of the Bid submitted by the Bidder.

Particulars	Sl. No.	Terms and Conditions	Compliance required	(Yes/No) with Deviation if any
Law	1	The Purchase Order (PO) shall be considered and made in accordance with the laws of India for the time being in force. The Purchase Order shall be governed by and interpreted in accordance with the laws of India.	Complied	
Effective Date of the Purchase Order (PO)	2	The PO shall come into effect on the date of issue of PO except when some other effective date is mutually agreed to and specifically indicated/provided in the PO and shall remain valid until the completion of the obligations of the parties under the contract.	Complied	
Acknowledgement of Purchase Order	3	Order acknowledgment should be sent within 6 business days. Non receipt of PO acknowledgment with the prescribed time will be treated as acknowledgment.	Complied	
Amendments	4	No provision of the Purchase Order shall be changed or modified in any way (including this provision) either in whole or in part except by an instrument in writing made after the date of this Purchase Order and which expressly states to amend the present Purchase Order.	Complied	
Termination of Purchase Order	5	The Buyer shall have right to terminate PO in part or in full in any of the following cases: (a) Bidder fails to supply the items/services as per the agreed specifications. (b) The delivery of the material is delayed for causes not attributable	Complied	

		to Force Majeure after the scheduled date of delivery with extension thereto if any. (c) The Seller is declared bankrupt or becomes insolvent. (d) As per decision of the Arbitration Tribunal.		
Notices	6	Any notice required or permitted by the contract shall be written in the English language and may be delivered personally or may be sent to e-mail/fax or post addressed to the latest address of the Party to whom it is sent.	Complied	
Arbitration	7.1	Any disputes or differences arising out of or in connection with the Purchase Order shall be settled by mutual amicable discussions. If this conciliation fails, unresolved disputes, if any, shall be resolved through Sole Arbitral Tribunal as per the provisions of the Arbitration & Conciliation Act, 1996 through the International Centre for Alternative Dispute Resolution (ICADR), Hyderabad, India under the ICADR Rules of Arbitration.	Complied	
	7.2	The venue for Arbitration proceedings shall be at Hyderabad, India.	Complied	
	7.3	All disputes shall be subjected to exclusive jurisdiction of the Courts in Hyderabad (GHMC) / Medchal – Malkajgiri District, notwithstanding concurrent jurisdiction of other courts of law.	Complied	
Penalty for use of Undue Influence	8	The Seller undertakes that he has not given, offered or promised to give, directly or indirectly, any gift, consideration, reward, commission, fees, brokerage or inducement to any person in service of the Buyer or otherwise in procuring the Contracts or forbearing to do or for having done or forborne to do any act in relation to the obtaining or execution of the present Contract or any other Contract with the Government of India for showing or forbearing to show favour or disfavour to any person in	Complied	

		<p>relation to the present Contract or any other Contract with the Government of India. Any breach of the aforesaid undertaking by the Seller or any one employed by him or acting on his behalf (whether with or without the knowledge of the Seller) or the commission of any offers by the Seller or anyone employed by him or acting on his behalf, as defined in Chapter IX of the Indian Penal Code, 1860 or the Prevention of Corruption Act, 1986 or any other Act enacted for the prevention of corruption shall entitle the Buyer to cancel the contract and all or any other contracts with the Seller and recover from the Seller the amount of any loss arising from such cancellation. A decision of the Buyer or his nominee to the effect that a breach of the undertaking had been committed shall be final and binding on the Seller. Giving or offering of any gift, bribe or inducement or any attempt at any such act on behalf of the Seller towards any officer/employee of the Buyer or to any other person in a position to influence any officer/employee of the Buyer for showing any favour in relation to this or any other contract, shall render the Seller to such liability/ penalty as the Buyer may deem proper, including but not limited to termination of the contract, imposition of penal damages, forfeiture of the Bank Guarantee and refund of the amounts paid by the Buyer.</p>		
Non-disclosure cum Confidentiality	9.1	The Bidder should keep all technical specifications, scope, details of equipment at and corresponding locations, terms and conditions, including, Drawings, Site Plans as confidential and shall not disclose to any third party, without prior written consent of ECIL.	Complied	
	9.2	When purchase order is awarded, the Bidder should undertake to treat purchase order and services to be rendered therein as absolutely confidential and shall not disclose or provide any information, which	Complied	

		may come to your knowledge or passed on to you during the execution by ECIL or end customer, to any third party, person or country under any circumstances without prior written consent of ECIL.		
	9.3	ECIL reserves the right to initiate legal action as per prevailing law against the Bidder and/or claim damages for non-compliance.	Complied	
Transfer and Sub-letting	10	The Seller has no right to give, bargain, sell, assign or sublet or otherwise dispose of the Contract or any part thereof, as well as to give or to let a third party take benefit or advantage of the present Contract or any part thereof.	Complied	
Tolerance Clause	11	To take care of any change in the requirement during the period starting from issue of RFQ till placement of the contract, Buyer reserves the right to 15% plus/minus increase or decrease the quantity of the required goods up to that limit without any change in the terms & conditions and prices quoted by the Seller. While awarding the contract, the quantity ordered can be increased or decreased by the Buyer within this tolerance limit.	Complied	
Taxes and Duties	12.1	Bidders must indicate separately the relevant Taxes/Duties likely to be paid in connection with delivery of completed goods specified in RFQ. In absence of this, the total cost quoted by them in their bids will be taken into account in the ranking of bids.	Complied	
	12.2	If a bidder is exempted from payment of any duty/tax up to any value of supplies from them he should clearly state that no such duty/tax will be charged by them up to the limit of exemption which they may have. If any concession is available in regard to rate/quantum of any Duty/tax, it should be brought out clearly. In such cases, relevant certificate will be issued by the Buyer later to enable the Seller to obtain exemptions from taxation authorities.	Complied	

	12.3	Any changes in levies, taxes and duties levied by Central / State governments such as CGST, SGST & IGST etc. on final product upward as a result of any statutory variation taking place within contract period shall be allowed reimbursement by the Buyer, to the extent of actual quantum of such duty/tax paid by the Seller. Similarly, in case of downward revision in any such duty/tax, the actual quantum of reduction of such duty/tax shall be reimbursed to the Buyer by the Seller. All such adjustments shall include all reliefs, exemptions, rebates, concession etc. if any, obtained by the Seller.	Complied	
	12.4	In case of extension of Delivery Period any increase in taxes, duties, levies etc. will not be paid to the seller unless the reasons for the delay are attributable to Buyer. In case of decrease the difference to be passed on to the buyer.	Complied	
GST	13.1	Bidders should quote GST separately in their quote. In the absence of any such stipulation in the bid, it will be presumed that the prices quoted by the Bidders are inclusive of GST and no liability of GST will devolve upon the Buyer.	Complied	
	13.2	On the Bids quoting GST extra, the rate, the type of GST – Centre, State, Integrated, Union Territory applicable at the time of supply should be shown separately. GST will be paid to the Seller at the rates mentioned in schedule of GST rates, based on the HSN code and as notified by the GST council.	Complied	
Paying Authority	14	The payment of bills will be made by ECIL-Hyderabad., based on the paying authority details in the contract. The following documents are to be submitted by the seller with the items for making the payment: (a) Ink-signed copy of Commercial invoice / Seller's bill.	Complied	

		<p>(b) Inspection note/ Duly signed test reports by Authorized agency for clearance of the goods</p> <p>(c) E-way Bill</p> <p>(d) Copy of Purchase Order</p> <p>(e) Packing list</p> <p>(f) Certificate of Conformity (COC) and Country of origin</p> <p>(g) Guarantee / Warranty certificate.</p> <p>(h) Performance Bank guarantee where applicable.</p> <p>(i) Order Amendments (if any)</p> <p>(j)Details for electronic payment viz. Account holder's name, Bank name, Branch name and address, Account type, Account number, IFSC code, MICR code, (in case of imports SWIFT Code and BIC number also).</p> <p>(k) Any other document / certificate that may be required as per the Purchase Order / Contract.</p>		
Fall clause	15	<p>The following Fall Clause will form part of the contract placed on successful Bidder:-</p> <p>(a) The price charged for the goods supplied under the contract by the Seller shall in no event exceed the lowest prices at which the Seller sells the goods or offer to sell goods of identical description to any persons/Organization including the purchaser or any department of the Central Government or any Department of the State Government or any statutory undertaking of the Central or State Government as the case may be during the period or till the performance of all Supply Orders placed during the currency of the contract is completed.</p>	Complied	

		<p>(b) If at any time, during the said period the Seller reduces the sale price, sells or offer to sell such goods to any person/organization including the Buyer or any Department of Central Government or any Department of the State Government or any Statutory undertaking of the Central or State Government as the case may be at a price lower than the price chargeable under the contract, the Seller shall forthwith notify such reduction or sale or offer of sale to ECIL and the price payable under the contract for the goods of such reduction of sale or offer of the sale shall stand correspondingly reduced. The above stipulation will, however, not apply to:-</p> <p>(i) Exports by the Seller.</p> <p>(ii) Sale of goods as original equipment at a price lower than the prices charged for normal replacement.</p> <p>(iii) Sale of goods such as drugs which have expiry dates.</p> <p>(iv) Sale of goods at lower price on or after the date of completion of sale/placement of the order of goods by the authority concerned under the existing or previous Contracts as also under any previous contracts entered into with the Central or State Government Departments, including their undertakings excluding joint sector companies and/or private parties and bodies.</p>	Complied	
Risk Purchase clause	16.1	Should the goods or any part thereof not be delivered within the time or times specified in the contract documents, or if defective delivery is made in respect of the goods or any part thereof, the Buyer shall after granting the Seller 60 days to cure the breach, be at liberty, without prejudice to the right to recover liquidated damages as a remedy for breach of contract, to declare the contract as cancelled either wholly or to the extent of such default	Complied	

	16.2	Should the goods or any part thereof not perform in accordance with the specifications / parameters provided by the SELLER during the check proof tests to be done in the BUYER's country, the BUYER shall be at liberty, without prejudice to any other remedies for breach of contract, to cancel the contract wholly or to the extent of such default.	Complied	
	16.3	In case of a material breach that was not remedied within 60 days, the BUYER shall, having given the right of first refusal to the SELLER be at liberty to purchase, manufacture, or procure from any other source as he thinks fit, other goods of the same or similar description to make good:- (a) Such default. (b) In the event of the contract being wholly determined the balance of the goods remaining to be delivered there under.	Complied	
	16.4	Any excess of the purchase price, cost of manufacturer, or value of any goods procured from any other supplier as the case may be, over the contract price appropriate to such default or balance shall be recoverable from the SELLER.	Complied	
	16.5	Such extra cost could be on account of either a higher unit price or any higher rate of foreign exchange conversion rate by such alternative procurement.	Complied	
	16.6	The recovery of such extra cost would be done from the available credit/future payables in the account of the defaulting supplier or by invocation of EMD/Bank Guarantee issued in favour of ECIL or through other means of law.	Complied	
	16.7	ECIL reserves right to invoke Risk Purchase Clause, without further notice, when	Complied	

		<p>(i) The supplier fails to deliver the equipment /materials/ services as per agreed specifications or</p> <p>(ii) When the supplier fails to provide PBG as per terms or</p> <p>(iii) When the LD reaches maximum or</p> <p>(iv) When the services during warranty period is not satisfactory.</p>		
Force Majeure clause	17.1	Neither party shall bear responsibility for the complete or partial nonperformance of any of its obligations (except for failure to pay any sum which has become due on account of receipt of goods under the provisions of the present contract), if the non-performance results from such Force Majeure circumstances as Flood, Fire, Earth Quake and other acts of God as well as War, Military operation, blockade, Acts or Actions of State Authorities, Epidemic, Pandemic, Government Guidelines or any other circumstances beyond the parties control that have arisen after the conclusion of the present contract.	Complied	
	17.2	In such circumstances the time stipulated for the performance of an obligation under the present contract is extended correspondingly for the period of time of action of these circumstances and their consequences.	Complied	
	17.3	The party for which it becomes impossible to meet obligations under this contract due to Force Majeure conditions, is to notify in written form the other party of the beginning and cessation of the above circumstances immediately, but in any case not later than 10 (Ten) days from the moment of their beginning.	Complied	
	17.4	Certificate of a Chamber of Commerce (Commerce and Industry) or other Competent Authority or organization of the respective country shall be a sufficient proof of commencement and cessation of the above circumstances.	Complied	

	17.5	If the impossibility of complete or partial performance of an obligation lasts for more than 6 (six) months, either party hereto reserves the right to terminate the contract totally or partially upon giving prior written notice of 30 (thirty) days to the other party of the intention to terminate without any liability other than reimbursement on the terms provided in the agreement for the goods received.	Complied	
Insurance	18	For purchase orders placed on FOR, ECIL basis the necessary insurance to ensure safe transit of material should be catered for by the supplier. The supplier will be responsible for shortage/damage during transit and as such the consignment may be insured by the supplier at his option and cost.	Complied	
Quality	19	The quality of the goods delivered according to the Contract shall correspond to the technical conditions and standards valid for the deliveries of the same goods for in Seller's country or specifications enumerated as per RFQ and shall also include therein modification to the goods suggested by the Buyer. Such modifications will be mutually agreed to as per amendments to the contract. The Seller confirms that the goods to be supplied under this Contract shall be new i.e. not manufactured before (Year of Contract),and shall incorporate all the latest improvements and modifications thereto and spares of improved and modified equipment are backward integrated and interchangeable with same equipment supplied by the Seller in the past if any. The Seller shall supply an interchangeability certificate along with the changed part numbers wherein it should be mentioned that item would provide as much life as the original item.	Complied	
Conditional Offer	20	No conditional offer will be accepted which is not in conformity with the technical specifications and terms & conditions mentioned in the	Complied	

		RFQ.		
Patents and Other Industrial Property Rights	21	The prices quoted by the bidders shall be deemed to include all amounts payable for the use of patents, copyrights, registered charges, trademarks and payments for any other industrial property rights. The Seller shall indemnify the Buyer against all claims from a third party at any time on account of the infringement of any or all the rights, whether such claims arise in respect of manufacture or use. The Seller shall be responsible for the completion of the supplies including spares, tools, technical literature and training aggregates irrespective of the fact of infringement of the supplies, irrespective of the fact of infringement of any or all the rights mentioned above.	Complied	
Conflict of Interest:	22	Any bidder having a conflict of interest, which substantially affects fair competition, shall not be eligible to bid in this tender. Bids found to have a conflict of interest shall be rejected as non-responsive. Bidder shall be required to declare the absence of such conflict of interest in Annexure D 'Eligibility Declarations'. A bidder in this Tender Process shall be considered to have a conflict of interest if the bidder: -(a) directly or indirectly controls, is controlled by or is under common control with another Bidder; or (b) receives or have received any direct or indirect subsidy/ financial stake from another bidder; or (c) has the same legal representative/ agent as another bidder for purposes of this bid. A Principal can authorize only one agent, and an agent also should not represent or quote on behalf of more than one Principal. However, this shall not debar more than one Authorised distributor from quoting equipment manufactured by an Original Equipment Manufacturer (OEM), in procurements under Proprietary Article Certificate; or	Complied	

	<p>(d) has a relationship with another bidder, directly or through common third parties, that puts it in a position to have access to information about or influence the bid of another Bidder or influence the decisions of the Procuring Entity regarding this Tender process; or</p> <p>(e) participates in more than one bid in this tender process. Participation in any capacity by a Bidder (including the participation of a Bidder as sub-contractor in another bid or vice-versa) in more than one bid shall result in the disqualification of all bids in which he is a party. However, this does not limit the participation of a non-bidder firm as a sub-contractor in more than one bid; or</p> <p>(f) would be providing goods, works, or non-consulting services resulting from or directly related to consulting services that it provided (or were provided by any affiliate that directly or indirectly controls, is controlled by, or is under common control with that firm), for the procurement planning (inter-alia preparation of feasibility/ cost estimates/ Detailed Project Report (DPR), design/ technical specifications, terms of reference (ToR)/ Activity Schedule/ schedule of requirements or the Tender Document etc) of this Tender process; or</p> <p>(g) has a close business or family relationship with a staff of the Procuring Organization who: (i) are directly or indirectly involved in the preparation of the Tender document or specifications of the Tender Process, and/or the evaluation of bids; or (ii) would be involved in the implementation or supervision of resulting Contract unless the conflict stemming from such relationship has been resolved in a manner acceptable to the Procuring Entity throughout the Tender process and execution of the Contract.</p>		
--	--	--	--

Consideration of Abnormally Low Bids:	23	An Abnormally Low bid is one in which the bid price, in combination with other elements of the bid, appears so low that it raises substantive concerns as to the Bidder's capability to perform the contract at the offered price. ECIL shall in such cases seek written clarifications from the Bidder, including detailed price analyses of its bid price concerning scope, schedule, allocation of risks and responsibilities, and any other requirements of the Tender Document. If, after evaluating the price analyses, ECIL determines that Bidder has substantively failed to demonstrate its capability to deliver the contract at the offered price, the ECIL shall reject the bid/ proposal, and evaluation shall proceed with the next ranked bidder.	Complied	
--	----	---	----------	--

Part IV – SPECIAL TERMS AND CONDITIONS

The Bidder is required to give confirmation of their acceptance of Special Conditions of the RFQ mentioned below which will automatically be considered as part of the Contract concluded with the successful Bidder. Failure to do so may result in rejection of the Bid submitted.

Particulars	Sl. No.	Terms and Conditions	Compliance required	(Yes/No) with Deviation if any
Certificate of Conformity	1	COC to be provided along with the supply of the TCE without which item will not be accepted. OEM COC shall be provided for any COTS items used.	Complied	
SPQ/MOQ	3	Bidder to indicate the applicable SPQ/MOQ, if any, in the Techno-Commercial and Price Bid.	Complied	
Terms of Price	2	The Price quoted by indigenous bidders are on FOR, ECIL basis to be delivered at In-charge, STORES, CNSG, ECIL, ECIL (POST), Hyderabad, Telangana. PIN - 500062	Complied	
Payment Terms	3	(a) 100% of payment will be made for each lot within 45 days from the date of receipt against acceptance of material at ECIL Stores, on submission of all required documents, such as Tax Invoice, Delivery Challans. Payment will be done on pro-rata basis in case material is received in partial shipments. (b) Payment of taxes will be made to the Seller after submission of tax remittance documents and uploading the tax return by the vendor, in turn invoice has to appear in GSTR2A of ECIL.	Complied	
		(c) In order to address the financial needs of MSE firms, GoI has introduced a platform facilitating the financing of their trade receivables, through multiple financiers which is termed as Trade Receivable Discounting System (TReDS). At TReDS, auctioning of invoices at competitive and transparent environment is done by financiers based on	Complied	

		<p>Buyers credit profile.</p> <p>(b) ECIL is registered on TReDS platform with “A-TReDSLtd.(Invoicemart)”. Desirous MSE Bidders/Vendors, who want to receive payments through TReDS platform, have to submit the invoice to ECIL along with the necessary requirements as per PO and the payment terms. Upon receipt and acceptance of the supplied materials/completion of services and receipt of invoices with mandated enclosures and after due certification of invoices with enclosures by commercial/material dept., Finance dept. shall upload the invoices on the Invoicemart, TReDS platform and process the invoices for payment. Post uploading on the platform, the financier would be bidding for the invoices and respective MSE vendors would be accepting the bid, so that they can get the disbursement from the Financier.</p> <p>(c) MSE bidders desirous to receive payment through TReDS platform may avail the facility if they are already registered on “Invoicemart” TReDS platform or by registering on it.</p>		
Warranty	4	The Seller hereby guarantees that the said goods/articles would continue to conform to the description and quality aforesaid for a period of 24 months/2year from the date of delivery of the said goods stores/articles to the Buyer or from the date of shipment/dispatch from the Seller’s works whichever is earlier for free replacement of Material rejected for Quality Issue / Failing the Specification as asked by ECIL at NO COST TO ECIL. Timely after sales support to be provided locally during warranty period.	Complied	
		a) If within the period of warranty, the goods are reported by the Buyer to have failed to perform as per the specifications, the Seller shall either replace or rectify the same free of charge, maximum within 15 days of		

		notification of such defect by the Buyer. (b) In case of delay beyond the above period, warranty of the unit would be extended by such duration of downtime. Record of the downtime would be maintained by User in log book.		
Performance cum Warranty Guarantee (PCWG)	5.1	Within 15 days of award of Letter of Intent (LOI), Successful Bidder should (i) Deposit an amount equal to 3% of Purchase Order Value through crossed Demand Draft drawn in favor of ‘Electronics Corporation of India Limited, Hyderabad’ and payable at Hyderabad (or) (ii) Through Bank Guarantee strictly as per format in Annexure E for 3% of Purchase Order value on a Scheduled Bank (except Co-Operative Banks) valid up to completion of the warranty period + 2 months from the date of issue of Bank Guarantee to cover the Bidder’s obligations on performance on the PO, warranty and technical support has to be furnished.	Complied	
	5.2	Purchase Order will be released within 6 working days after receipt of PCWG. The delivery schedule will be considered from the date of LOI.	Complied	
	5.3	If the Guarantee is furnished by way of Bank Guarantee, the same should be extended from time to time to serve the intended obligation of Bidder, failing which ECIL reserves the right to invoke the Bank Guarantee. If the Bidder fails to furnish the Guarantee, ECIL reserves the right to cancel LOI and not place the PO.	Complied	
Liquidated Damages	6	In the event of the Seller's failure to supply the items, services including installation, training and trials etc. as specified in the Purchase Order, the Buyer may, at his discretion, withhold any payment until the completion of the contract. The BUYER may also deduct from the SELLER as	Complied	

		agreed, liquidated damages to the sum of 0.5% of the contract price of the delayed / undelivered items and services mentioned above for every week of delay or part of a week, subject to the maximum value of the Liquidated Damages being not higher than 10% of the value of delayed / undelivered items / services.		
Inspection	7	<p>a. The Inspection of items/equipment will be carried out by the inspection agency of ECIL/USER at ECIL premises as the case may be.</p> <p>b. In the event of shortage / damage noticed upon receipt and opening of packages at ECIL Stores, all such shortages or damages shall be made good by the bidder within 10 days from the date of reporting, free of all charges.</p> <p>c. All required test instruments, accessories, jigs, simulator to be provided by Supplier during testing / inspection. The inspection includes the Physical, Mechanical Inspection and Electrical testing.</p>	Complied	
Franking Clause	8	<p>The following franking clause will form of the part of the Purchase Order placed on Successful Bidders:</p> <p>(a) In case of Acceptance of Store(s): The fact that the goods have been inspected after the delivery period and passed by the Inspecting Officer will not have the effect of keeping the contract alive. The goods are being passed without prejudice to the rights of the buyer under the terms and conditions of the Contract.</p> <p>(b) In Case of Rejection of Store(s): The fact that the goods have been inspected after the delivery period and rejected by the Inspecting Office will not bind the Buyer in any manner. The goods are being rejected without prejudice to the right of the Buyer under the terms and conditions of the Contract</p>	Complied	

<p>Packing and Marking Instructions</p>	<p>9</p>	<p>(a) The Seller shall provide packing and preservation of the items to be delivered in physical form so as to ensure their safety against damage in the conditions of Land, Sea and air transportation, transshipment, storage and weather hazards during transportation and handling.</p> <p>(b) The Seller shall ensure that the stores are packed in containers, which are made sufficiently strong, and with seasoned wood, where required.</p> <p>(c) The packing cases should have hooks for lifting by crane/fork lift truck.</p> <p>(d) Tags with proper marking shall be fastened to the special equipment, which cannot be packed.</p> <p>(e) A label in English shall be either pasted on the carton or painted indicating the under mentioned details of the items contained in the carton. The cartons shall then be packed in packing cases as required.</p> <p>(i) Packing List: (ii) Buyer Details: (iii) Seller Details: (iv) Consignee Details: (v) Purchase Order No: (vi) Package No.: (vii) Part Number: (viii) Nomenclature: (ix) Quantity contracted:</p> <p>(f) If necessary, each package shall be marked with warning inscriptions: TOP, "DO NOT TURN OVER", category of cargo, etc.</p> <p>(g) One copy of the packing list in English shall be inserted in each cargo package.</p> <p>(h) Supplier Part No and ECIL Part Nos should be present on all the</p>	<p>Complied</p>	
--	----------	---	-----------------	--

		items including LRU, Cable Assemblies and accessories etc., ECIL will provide the list of approved Part Numbers for all the cables & accessories which are part of the above items. All accessories which are not integrated into the shelter to be supplied in separate Packing Box.		
Technical Literature & Training	10	The complete Technical Literature mentioned in list of documents in Annexure-A should be supplied by the bidder which are relevant to the tendered items.	Complied	
Quality Assurance	11.1	The item should be of the latest manufacture, conforming to the current production standard and having 100% defined life at the time of delivery.	Complied	
	11.2	Item will be tested against mutually agreed ATP doc & clearance shall be based on the ATR	Complied	
Purchase Preference for MSE Vendors	12.1	Purchase preference will be given to MSEs as defined in Public Procurement Policy for Micro and Small Enterprises (MSEs) Order, 2012 dated 23.03.2012 issued by Ministry of Micro, Small and Medium Enterprises and its subsequent Orders/Notifications issued by concerned Ministry. If the bidder wants to avail the Purchase preference, the bidder must be the manufacturer of the offered product in case of bid for supply of goods. Traders are excluded from the purview of Public Procurement Policy for Micro and Small Enterprises. In respect of bid for Services, the bidder must be the Service provider of the offered Service. Relevant documentary evidence in this regard shall be uploaded along with the bid in respect of the offered product or service. (b) If L-1 is not an MSE and MSE Supplier(s) has/have quoted price within L-1+ 15% (where MSE Purchase Preference is applicable) of	Complied	

		<p>margin of purchase preference /price band defined in relevant policy, such Supplier shall be given opportunity to match L-1 price and contract will be awarded for 100% percentage of total quantity (if MSE Purchase Preference is applicable).</p> <p>(c) It is advised to refer the OM No.F.1/4/2021-PPD dated18.05.2023 for compliance of Concurrent application of Public Procurement Policy for Micro and Small Enterprises Order, 2012 and Public Procurement (Preference to Make in India) Order, 2017.</p> <p>(d) The MSE Vendor has to submit the Copy of Udyam Registration Certificate along with relevant supporting documents.</p>		
Relaxation for Start-ups:	13	<p>a) Prequalification Criteria with respect to Prior Turnover and Prior Experience may be relaxed for Start-ups (whether MSEs or otherwise) as per the Government of India guidelines.</p> <p>(b) The bidder who intends to participate as “Start-up” company should enclose the Certificate of Recognition issued by Department of Industrial Policy and Promotion, Ministry of Commerce & Industry, Govt. of India during submission of Technical bid.</p> <p>(c) The following declaration should be given by Start-ups at the time of tender submission: “We are a ‘Start-up’ company and we are enclosing copy of certificate of recognition issued by Department of Industrial Policy and Promotion, Ministry of Commerce & Industry, Govt. of India.”</p>	Complied	
Restrictions under Rule 144(xi) of GFR 2017	14	<p>The Provisions contained in Order (Public Procurement No.1) of DOE, Public Procurement Division, No. F.No.6/18/2019-PPD, dt. 23.7.2020 and as amended / clarified from time to time, shall be applicable to this tender. Details are at Annexure F.</p> <p>A certificate for the same as per the format mentioned at Annexure Fis to be submitted by the bidder.</p>	Complied	

Year of Production	15	Supplies should be of latest manufacture, conform to the current production standard and should have 100% of the defined life at the time of delivery. Deviations if any should be clearly brought out by the vendor in the Commercial Proposal.		
In Service Life / Shelf Life Product support and upgradeability	16	Product support for at least 10 years from the date of delivery. During this period, it is the responsibility of the vendor to intimate ECIL of any last buy options and also suggesting any up gradation options with minimal, backward-compatible, in-situ changes, well in 2 years advance.	Complied	
Government Regulations	17	It must be confirmed that there are no Govt. restrictions or limitations in the country or countries from which sub-components or sub-modules are being procured.	Complied	

5. PART – V PRICE BID FORMAT

This format is for indicative purpose only. There is no need to attach any price information in the techno-commercial part of the bid.

1	2	3	4	5	6	7	8
Sl. No.	Item Description	Qty. Required	Currency	Unit Material Cost	Total Material Cost	Taxes	Total Material Cost with taxes
1.	Supply of Test Control Equipment as per Annexure-A	01 set	INR				

Notes:

S. No.	Terms and Conditions	Compliance required	Yes/No with Deviation
1	The Lowest Bid will be decided upon the lowest price quoted by the particular Bidder as per the Price Format given in our portal. The consideration of taxes and duties in evaluation process will be as follows: In cases where only Indian Bidders are competing, L-1 bidder will be determined on all elements of costs excluding taxes and duties, etc. quoted by the Bidders.	Noted	
2	The Lowest Acceptable Bid will be considered further for placement of Purchase Order after complete clarification and price negotiations, if any, as decided by the Buyer.	Noted	
3	If there is any discrepancy between the unit price and the total price the unit price will prevail. If there is a discrepancy between words and figures, the amount in words will prevail for calculation of price.	Noted	
4	The prices of L1 among Techno-commercially qualified bids will be considered further for placement of Purchase Order after complete clarification and price negotiations, if any, as decided by the Buyer based on total value wise evaluation criteria.	Noted	
5	Price Bid: The price bid format is as per the format given in the financial offer of the ECIL e-Procurement portal.	Noted	
6	The basic prices should be offered on INR against each line entry, inclusive of packing forwarding, freight, insurance, unloading & including all other incidental as per our on line portal.	Agreed	
7	The quoted price will only be considered till 2 decimal places	Agreed	

(refers to Para 1 of Part II, refers to Para 10 of Part IV)

Technical Specification of Test Control Equipment (TCE)

The Test Control Equipment (TCE) is a Test Jig required for validating the functionality of the System Under Test (SUT) by simulating the synthetic radar environment. The purpose of this equipment is to simulate an RF environment, including radar target echoes that incorporate Range, Doppler, RCS, and power level simulations in Ku Band. The system shall preferably be COTS based system.

Following functionalities are required

- TCE shall generate all the control & RF signals required for testing the SUT subsystem & system. Also it shall facilitate means to debug the SUT in case of failure.
- It shall provide means to record information from SUT during all functional tests.
- It should also implement ECM techniques with RGPO and VGPO. Additionally, it shall simulate radar target and noise jamming signals.
- It must communicate all the relevant parameters to SUT through MIL-STD-1553 B interface. It shall also generate 1PPS signals via the RS422 interface.
- Exact Frequency of operation shall be communicated to the successful bidder after placement of order.
- The system shall include facility for logging MIL1553B data & Ethernet data from SUT and displaying the data in the GUI.
- A user-friendly application GUI is required to be developed for defining required RF environment by user.
- At 1msec rate the simulated target details (Range, Doppler, Attenuation) must be logged in to file with local time stamp
- For characterization and performance evaluation of TCE with SUT, SUT will be made available by the buyer.

The logical block diagram of TCE is shown below. The TCE consist of

1. DRFM based Radar Target Echo Simulator (RTES),
2. Up Down Convertor,
3. Processor based Controller ,
4. MIL1553 B card –Single channel multifunction with PCIe or PXI interface
5. RS 422 Interface card,

6. Power Supplies and Power Relays
7. Associated test cables.

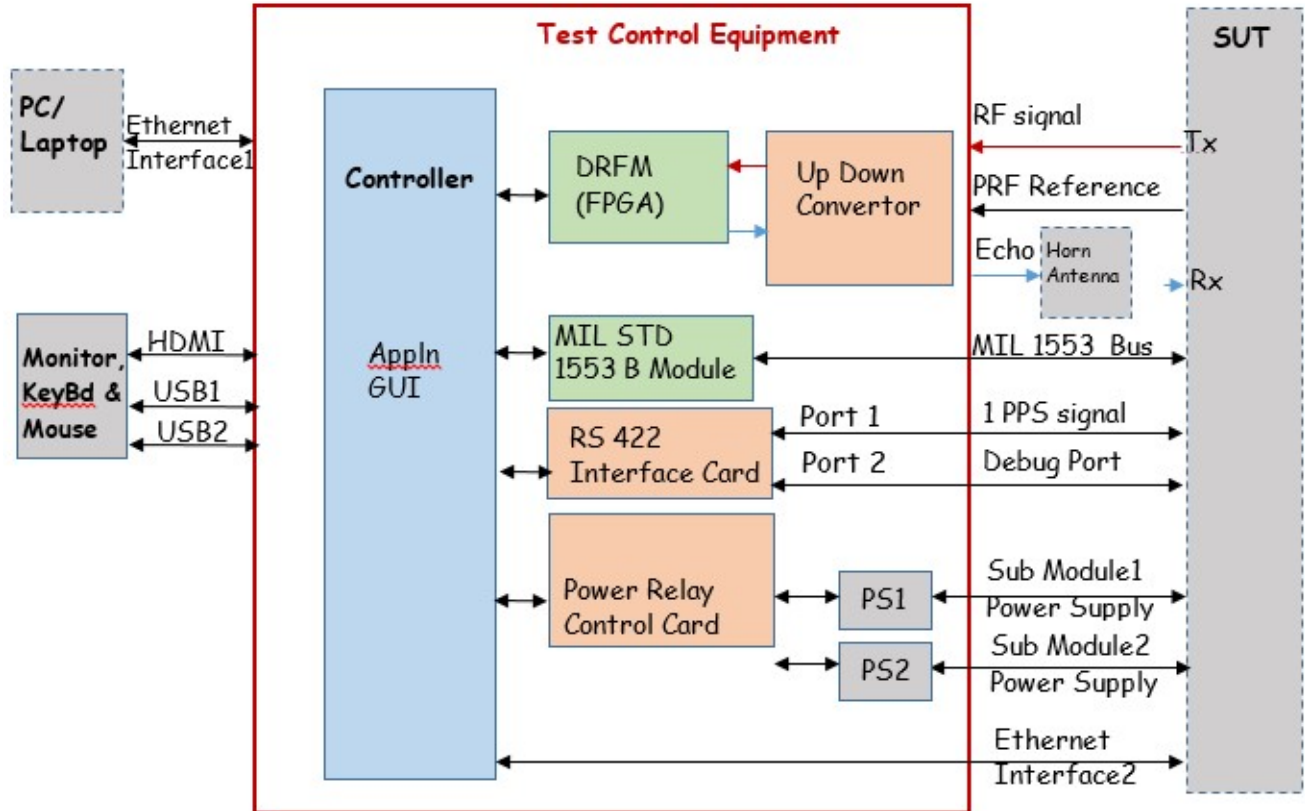

It should process the received radar signal to add multiple echoes and jamming waveforms and transmit the echoes back to radar in real-time.

1.1 Specification

S. No.	Description	Specification
1.	Input Frequency range	Ku Band(12-18GHz)
2.	Input RF Bandwidth	$F_c \pm 100\text{MHz}$ min
3.	Type Of Input and Output connectivity	SMA(F) for input and output
4.	Target Parameter Update rate (internal)	100 usec max
5.	Max Input power level without damage	+ 15 dBm
6.	Output RF power range	0 dBm to -120 dBm using digital Step Attenuator RF output Power to be maintained irrespective of variations in the input power of RF reference.
7.	Instantaneous Dynamic Range for Echo output	30 dB (for RCS and Target to target Variations)

		90 dB (for variations when only one target is generated)
8.	Output Amplitude level accuracy	± 0.5 dB
9.	Average RCS	0 to 30dB
10.	RCS models	Swerling model 1 to 5
11.	Isolation between Tx& Rx path	>60dB
12.	Minimum Target range	0.25 Km
13.	Maximum Target range	30 Km
14.	Resolution of Target Range simulation	≤ 1 m
15.	Target velocity & acceleration (Max.)	± 7000 m/s and ± 30g
16.	Target velocity Resolution	1 m/sec
17.	Communication channels	a. GUI running on the TCE with all the software licenses for the entire setup(perpetual) b. MIL-STD-1553 B –PCIe or PXI based.
		c. Ethernet Interface(1 GbE) to communicate with remote PC.
		c. Ethernet Interface(1 GbE) to communicate with SUT d. RS422 interface- 2 Ports 1stport :1 PPS signals shall be made available to the SUT to synchronize the MIL1553 signal of TCE with SUT . 2nd Port : for Debug
		USB port (2 Nos) to connect Keyboard & Mouse.
18.	Log file support	At 1msec rate, the simulated target details (range, Doppler, Attenuation/output signal level, Acceleration) must be logged in to file with local time stampfor a duration of 1 hour.
19.	Power Supply for TCE	230 V AC ± 10 % , 50 Hz
20.	Input to TCE	System must be able to take pulsed RF through RF reference connector as well as separate RF & Pulse signals from Pulse & RF Reference connectors
a.	Pulse Waveform	
	i. PRF	5 KHz to 600 KHz
	ii. Pulse Width	0.5us to 5 us
	iii. Connector	SMA(F)
b.	RF Reference	
	i. RF	Ku Band
	ii. Power	-35 dBm to 0 dBm
	iii. Connector	SMA(F)
21.	Output from TCE	
a.	RF Output	

	i. Output Frequency velocity	$F_c \pm F_d$
	ii. Rise time and fall time of pulse modulator	10 ns for both (desirable)
	iii. Connectors	SMA(F)
	iv. Spurious	-60dBc
b.	Power Supply to SUT:	
	i. Submodule 1 Power Supply : 01 Nos (28V \pm 8V,15 A Max)	D38999 Circular Connector
	ii. Submodule2 Power Supply : 01 Nos (28V \pm 8V,38 A Max)	D38999 Circular Connector
	1. Power ON control for Submodule 1 Power Supply& Submodule 2 Power Supply shall be through hard control and soft control through GUI. 2. Part No of the circular connector shall be specified to the L1 Vendor.	
22.	No of Targets	<ul style="list-style-type: none"> i. Minimum 2Targets ii. All targets shall be generated simultaneously with a provision of generating both as overlapping targets iii. Provision to output the signal of two targets separately on two separate RF connectors or combine them internally and output on a single RF connector through software control.
24	Types of Noise Jamming	Spot, Barrage and sweep.
25	Deceptive Jamming	Range and velocity gate pull off (RGPO & VGPO) – 1 No each Both shall work in sync.
26	Jammer output power	Considering a real scenario of jammer at 20 Km distance with following characteristics, the TCE jammer output power must be varied 1.Barrage noise jamming with spectrum bandwidth of up to 200 MHz 2.Spot Noise jamming in frequency with spectrum bandwidth of up to 1 MHz 3.VGPO jamming with pull off range \pm (5 to 50) KHz, pull off cycle (1 to 8)sec 4.RGPO jamming with pull off range 5-15us,pull off cycle (0.4-1. 2)sec
27	Control of SUT supply & Modes	SUT modes of operation and supply to switch to power ON SUT sub modules to be controlled through TCE using appropriate relay control card. Also provision for manual control to power on SUT shall be given
28	Mechanical Dimensions & Weight (Not Exceeding)	19”Rack Mountable ,6U(Height), \leq 40 Kgs Weight with \pm 2Kgs tolerance

1.2 Scope of work

Following terms shall be strictly addressed by the vendor without which the bid will be rejected.

1. The vendor shall design and develop Test Control Equipment meeting Tender technical specifications, scope of work & Terms and conditions.

1. As a part of technical bid submission, the vendor shall provide the detailed technical proposal covering the HW architecture, system design, and realization approach, compliance matrix for all the specification, scope of work, terms and condition mentioned in the tender enquiry.

2. The TCE shall simulate the following on the RF output channel (Echo Signal) by user programmable through GUI.

- Target skin return signals
- Target skin return signals with noise jamming
- Target skin return signals with deceptive jamming
- Target skin return signals with combination of noise jamming & deceptive jamming

3. The system should be developed based on DRFM configuration and it should operate in real-time on FPGAs.

4. The communication with SUT is through MIL1553B communication protocols, including BC to RT and RT to BC data transfers.

5. MT data logging captures communication data which shall be stored in files for later analysis and visualized in graphical formats.

6. Along with the system delivery, technical data sheets, & warranty certificate (in original) shall be submitted.

7. GUI shall be developed such that user can enter the

- a) Radar parameters like Transmitter power, Antenna Gain & Beamwidth, frequency of operation, Kinematics: Range, Velocity, Acceleration, and radar system losses, type of atmosphere, temperature, humidity etc.
- b) Target parameters like Position, Velocity, Acceleration, & Radar Cross Section (Swirling Model).
- c) ECM techniques, along with noise jamming parameters, shall be configurable, allowing for adjustments such as noise bandwidth and offset for noise jamming.

Additionally, for RGPO and VGPO, will have the time constraints for each stage of the parameters that can be configurable.

8. During run time, all the simulation parameters like Range, Velocity, Acceleration etc shall be stored in a file for a duration of 1 hour . (Required for offline analysis).
9. In the GUI, provisions shall be made available to enter the test facility plumbing loss (dB) and its propagation delay (μ s). Required compensations shall be incorporated. For all test cases, the maximum power available at the output of the TCE shall be limited to 0dBm.
10. Provision shall be made for Built-in-test/BITE for all hardware which shall be controlled thru GUI.
11. Provision will be made available to have an automatic gain control (AGC) inside TCE at either RF or IF or Baseband stage such that for any signal levels (in the dynamic range) the RF output power level limited to 0dBm . (under no applied losses condition) However, AGC will be user selectable based on user command.
12. System input/output power dynamic range, linearity shall be calibrated at user defined frequency & over entire instantaneous bandwidth IBW
13. The TCE should provide full output dynamic range in terms of power linearity irrespective of input power levels (within Dynamic Range) & frequency of operation.
14. All such parameters will be well calibrated for input power dynamic Range & over the entire frequency band
15. System shall be made operational on 24x7 day basis under room temperature (< 24 degC). Vendor must cater for system heat management.
16. The Preliminary Design Document (PDR) shall be prepared with detailed description about system configuration including overall system block diagram, architecture, configuration, interconnectivity diagram between modules, criteria for selecting a modules/sub modules and software shall be clearly defined meeting each specification.
17. The test cases in the Acceptance Test Plan (ATP) document shall be prepared on mutual understanding between the buyer and the vendor based on the system requirement covering all specification.
18. The vendor shall demonstrate the TCE by loading working executable, drivers during ATP.
19. Vendor shall deliver the system as per the List of deliverables.
20. Vendor shall deliver the OEM COC for COTS items and vendor COC for the system.

21. The vendor should have delivered a similar system to any Govt organization like DRDO or PSU and purchase order copy to be enclosed with the techno-commercial bid.
22. Accordingly vendor should arrange a demonstration of the same to the TEC committee during TEC for any frequency Band (X/Ku/Ka) covering Range, Doppler for moving target, Range resolution, Maximum RF output power irrespective of RF input power and swerling RCS models.
23. Vendor should have an average turnover of Rs40 Lakhs for the last three financial years and should not have incurred losses in the last three financial years. Audited financial reports must be submitted for the same.
24. Entire system should be supplied in a single LOT including list of deliverables.
25. Hands on training for a team of 02 engineers shall be given at ECIL on the configuration, Operation, Fault diagnosis and rectification procedure for the TCE.

List of Deliverables:

S No	Item	Quantity
1	Test Control Equipment as per the specification a) Controller b) FPGA based DRFM c) Up Down Convertor d) Mil 1553B PCIe or PXIe based card e) RS422 interface Card f) Two Power supply with power relay control g) Ethernet Interface h) Monitor i) Key board & Mouse to connect TCE.	1 set
	All external cable assemblies with mating connectors. a) Twinax MIL-1553B cable -1 No b) RF Cable (3 Nos) c) RS422 port1 Cable -1 No d) RS422 port2 Cable -1 No e) 1GbE Ethernet cable (10Mt)-1 No, f) 1GbE Ethernet cable (5Mt)-1 No, g) Monitor HDMI cable – 1 No, h) PS1 mating cable -1 No i) PS2 mating cable-1 No	1 Set
	Applicable source codes , drivers ,executables & application GUI	Soft Copy
	Documents: a) Warranty Certificate b) Preliminary Design Document (PDR),	1 Hard and

	<ul style="list-style-type: none"> c) Critical Design Review (CDR) d) Electrical & Mechanical Interface Control Document (ICD), e) Cable Drawings f) Acceptance Test Plan(ATP) , g) Acceptance Test Report(ATR), h) Technical reference User Manual Functional, Mechanical, Electrical aspects 	Soft copy
	Delivery ,Installation, Training ,Acceptance Test	1 Job

(ON THE LETTER HEAD OF THE COMPANY)

Bid Security Declaration Form

Date: _____

Tender No. _____

To
ECIL,
ECIL (Post), Hyderabad

In accordance with Government of India, Ministry of Finance OM No. F.9/4/2020-PPD dated 12.11.2020

1. I/We accept that I/We will, automatically be suspended from being eligible for participating in bidding for any contract with you for the period of 1 (One) year, in case of, and starting from the date of, breaching our obligation(s) under the bidding conditions due to:
 - a) Withdrawing our bid, or any part of our bid, during the period of bid validity against the Tender No. _____ or any extension of the period of bid validity which we subsequently agreed to;
 - or
 - b) Having been notified of the acceptance of our bid by you during the period of bid validity,
 - (i) Failing or refusing to execute the Contract, or
 - (ii) Failing or refusing to furnish the performance security, if required, in accordance with the Instructions to Bidders.
2. I/We understand this Bid Security Declaration shall expire if we are not the successful Bidder.

Signed:

[signature of person whose name and capacity are shown below]

Name: [name of person signing the Bid Security Declaration], in the capacity of [legal capacity of person signing the Bid Security Declaration]

Duly authorized to sign the bid for and on behalf of: [Name of Bidder]

Dated on _____ day of _____, 20__

[Corporate Seal (where appropriate)]

PRE-BID QUERY FORMAT

Sl.No.	Section No.	Page No.	Clause as per RFQ	Clarification sought

(To be submitted as part of Techno-Commercial bid)

(On Company Letter-head)

(Along with supporting documents, if any)

Tender No.

Bidder's Name _____

[Address and Contact Details]

Bidder's Reference No. _____ Date.....

Eligibility Declarations

(Please tick appropriate boxes or cross out any declaration not applicable to the Bidder)

We hereby confirm that we are comply with all the stipulation of Tender Document clauses and declare as under and shall provide evidence of our continued eligibility to the Procuring Entity as may be requested:

1. **Legal Entity of Bidder:** _____
2. **OEM/ Manufacturer/ Agent/ Dealership Status:** _____
3. We are/ are not a JV _____
4. We solemnly declare that we (including our affiliates or subsidiaries or constituents):
 - (a) are not insolvent, in receivership, bankrupt or being wound up, not have our affairs administered by a court or a judicial officer, not have our business activities suspended and are not the subject of legal proceedings for any of these reasons;
 - (b) (including our Contractors/ subcontractors for any part of the contract):
 - (i) Do not stand declared ineligible/ blacklisted/ banned/ debarred by the Procuring Organization or its Ministry/ Department from participation in its Tender Processes; and/ or
 - (ii) Are not convicted (within three years preceding the last date of bid submission) or stand declared ineligible/ suspended/ blacklisted/ banned/ debarred by appropriate agencies of Government of India from participation in Tender Processes of all of its entities, for offences mentioned in Tender Document in this regard. We have neither changed our name nor created anew "Allied Firm", consequent to the above disqualifications.
 - (c) We certify that we fulfil any other additional eligibility condition if prescribed in Tender Document.

- (d) We have no conflict of interest, which substantially affects fair competition. The prices quoted are competitive and without adopting any unfair/ unethical/ anticompetitive means. No attempt has been made or shall be made by us to induce any other bidder to submit or not to submit an offer to restrict competition.

5. Restrictions on procurement from bidders from a country or countries, or a class of countries under Rule 144 (xi) of the General Financial Rules 2017:

We certify as under:

“We have read the clause regarding restrictions on procurement from a bidder of a country which shares a land border with India and on sub-contracting to contractors from such countries, and solemnly certify that we fulfil all requirements in this regard and are eligible to be considered. We certify that:

- (a) *we are not from such a country or, if from such a country, we are registered with the Competent Authority (copy enclosed). and;*
- (b) *we shall not subcontract any work to a contractor from such countries unless such contractor is registered with the Competent Authority.*

6. MSME Status:

Having read and understood the Public Procurement Policy for Micro and Small Enterprises (MSEs) Order, 2012 (as amended and revised till date), and solemnly declare the following:

- (a) We are – Micro/ Small/ Medium Enterprise/SSI/Govt.Deptt./PSU/ Others:.....
- (b) We attach herewith, Udyam Registration Certificate with the Udyam Registration Number as proof of our being MSE registered on the Udyam Registration Portal. The certificate is the latest up to the deadline for submission of the bid.
- (c) Whether Proprietor/ Partner belongs to SC/ ST or Women category. (Please specify names and percentage of shares held by SC/ ST Partners):.....

7. Start-up Status

We confirm that we are/ are not a Start-up entity as per the definition of the Department of Promotion of Industrial and Internal Trade – DPIIT.

8. Make in India Status:

Having read and understood the Public Procurement (Preference to Make in India) Order, 2017 (as amended and revised till date) and related notifications from the relevant Nodal Ministry/ Department, and solemnly declare the following:

(a) Self-Certification for the category of suppliers:

(Provide a certificate from statutory auditors/ cost accountant in case of Tenders above Rs 10 Crore for Class-I or Class-II Local Suppliers). Details of local content and location(s) at which value addition is made are as follows:

Local Content and %age	
Location(s) of value addition	

Therefore, we certify that we qualify for the following category of the supplier (tick the appropriate category):

- Class-I Local Supplier/
- Class-II Local Supplier/
- Non-Local Supplier.

(b) We also declare that

- There is no country whose bidders have been notified as ineligible on a reciprocal basis under this order for an offered Goods, or
- We do not belong to any Country whose bidders are notified as ineligible on a reciprocal basis under this order for the offered Goods.

9. Penalties for false or misleading declarations:

We hereby confirm that the particulars given above are factually correct and nothing is concealed and undertake to advise any future changes to the above details. We understand that any wrong or misleading self-declaration would violate the Code of Integrity and attract penalties as mentioned in this Tender Document.

.....
(Signature with date)

.....
(Name and designation)

Duly authorized to sign bid for and on behalf of

.....
.....
[name & address of Bidder and seal of company]

PERFORMANCE BANK GUARANTEE (FORMAT)

To

M/s Electronics Corporation of India Limited

Communication Systems Group
ECIL (P.O), Hyderabad – 500 062

Bank Guarantee in respect of Contract No. _____ Dated _____ between M/s. Electronics Corporation of India Limited and _____ (Name of the Supplier).

This Deed of Guarantee made this _____ day of _____, Two Thousand _____ between _____ (Name of the Bank with address), (hereinafter called the ‘Guarantor’), which expression shall unless repugnant to the context or meaning thereof be deemed to include its successors and assigns of the One Part, and

Electronics Corporation of India Limited, (a Government of India Enterprise), a Company incorporated under the Companies Act, 1956, having its Registered Office at Hyderabad – 500062, India (herein after called the ‘Company’), which expression shall unless repugnant to the context or meaning thereof be deemed to include its successors and assigns, of the Other Part.

Whereas M/s _____ (Supplier/Contractor/Company Name and address) (herein after referred to as the Contractor) was awarded contract No. _____ dated _____ (hereinafter referred to as the Contract) by the Company for _____ (Scope of Work). And whereas the contract inter-alia, provides that the Supplier shall furnish Bank Guarantee to the Company a sum of Rs. _____ (Rupees _____ only) towards due and faithful performance of the contract in the form and manner specified therein covering the obligations of the contractor.

And whereas the contractor has approached the Guarantor and in consideration of the arrangement arrived at between the contractor and the Guarantor, the Guarantor has agreed to give Guarantee as hereinafter mentioned in favour of the Company.

Now this Deed witnesses as follows:

1. The Guarantor do hereby guarantee to the Company the due and faithful performance, observance or execution of the contract by the Supplier and further unconditionally and irrevocably undertake to pay to the Company without demur and merely on a demand, to the extent of Rs. _____ (Rupees _____) when claim is made by the Company on them for any loss, damage, costs, charges and expenses caused to or suffered by the Company by reason of the contractor making any default in the performance, observance or execution of the terms, conditions, stipulations or undertakings or any one of them as contained in The contract.
2. The decision of the Company whether any default has occurred or has been committed by the contractor in the performance, observance, discharge, execution of any of the terms, conditions,

stipulations or undertakings or any one of them as contained in the contract and/or as to the extent of loss or damage costs, charges and expenses caused to or suffered by the Company by reason of the contractor making any default in the performance, observance or discharge of any of the terms, conditions, stipulations or undertakings or any one of them shall be conclusive and binding on the Guarantor, irrespective of the fact whether the contractor admits or denies the faults or questions the correctness of any demand made by the Company in any Court, Tribunal or Arbitration proceedings or before any other Authority.

3. The Company shall have the fullest liberty without affecting in any way the liability of the Guarantor under this Guarantee from time to time to vary any of the terms and conditions of the contract or extend time of performance by the Supplier or to postpone for any time and from time to time any of the powers exercisable by it against the said contractor and either to enforce or forbear from enforcing any of the said terms and conditions governing the said contract and the Guarantor shall not be released from its liability under these presents and the liability of the Guarantor here under shall remain in full force and effect notwithstanding any exercise by the Company of the liberty with reference to the matters aforesaid or by reason of time being given to the contractor or any other forbearance, act or omission on the part of the Company or any indulgence by the Company to the said contractor or of any other matter or thing whatsoever which under the law relating to sureties, would, but for this provision have the effect of so releasing the Guarantor from its liability under this Guarantee.
4. The Guarantor further agrees that the Guarantee herein contained shall remain in full force and effect during the period that would be taken for the performance of the contract and its claims satisfied or discharged and till the Company certifies that the terms and conditions of the contract have been fully and properly carried out by the contractor and accordingly discharges this Guarantee subject to, however, that the Company shall have no claim under this Guarantee after ___ (months) from the date of completion of the contract, as the case may be, unless a notice of the claim under this Guarantee has been served on the Guarantor before the expiry of the said period in which case the same shall be enforceable against the Guarantor notwithstanding the fact that the same is enforced after the expiry of the said period.
5. The Guarantor undertakes not to revoke this Guarantee during this period it is in force except with the previous consent of the Company in Writing, and agree that any liquidation or winding up or dissolution or any change in the constitution of the contractor or the Guarantor shall not discharge the Guarantor's liability hereunder.
6. It shall not be necessary for the Company to proceed against the contractor before proceeding against the Guarantor and the Guarantee herein contained shall be enforceable against them notwithstanding any security, which the Company may have obtained or obtained from the contractor shall, at the time when the proceedings are taken against the Guarantor hereunder be outstanding or unrealized.

7. The Guarantor hereby declares that it has power to execute this Guarantee under its Memorandum and Articles of Association and the executants has full powers to do so on its behalf and the Power of Attorney dated _____, granted to him/her by the proper authority of the Guarantor.
8. This Guarantee is valid till _____ and the Company is entitled to lodge its claim on the Guarantor on or before _____ (additional 1 year). The Guarantor hereby undertakes to honour the said invocation without demur.

Witness:

Signed for and on behalf of the Bank (Guarantor)

- 1.
- 2.

Restrictions under Rule 144 (xi) of General Financial Rules 2017

1. The Provisions contained in Order (Public Procurement No.1) of DOE, Public Procurement Division, No. F.No.6/18/2019-PPD, dt. 23.7.2020 and as amended / clarified from time to time, shall be applicable to this tender.
2. The following clauses are to be treated as part of Instructions to Tenderers.
 - (a) Any bidder from a country which shares a land border with India will be eligible to bid against this tender only if the bidder is registered with the Competent Authority specified in Annex-I of Order (Public Procurement No.1) Dated 23.07.2020.
 - (b) “Bidder” (including the term ‘tenderer’, ‘consultant’ or ‘service provider’ in certain contexts) means any person or firm or company, including any member of a consortium or joint venture (that is an association of several persons, or firms or companies), every artificial juridical person not falling in any of the descriptions of bidders stated hereinbefore, including any agency branch or office controlled by such person, participating in procurement process.
 - (c) “Bidder from a country which shares a land border with India” for the purpose of this order means:-
 - (i) An entity incorporated, established or registered in such a country; or
 - (ii) A subsidiary of an entity incorporated, established or registered in such a country; or
 - (iii) An entity substantially controlled through entities incorporated, established or registered in such a country; or
 - (iv) An entity whose beneficial owner is situated in such a country; or
 - (v) An Indian (or other) agent of such an entity; or
 - (vi) A natural person who is citizen of such a country; or
 - (vii) A consortium or joint venture where any member of the consortium or joint venture falls under any of the above.
 - (d) The beneficial owner for the purpose of (iii) above will be as under:
 - (i) In case of a company or Limited Liability Partnership, the beneficial owner is the natural person(s), who, whether acting alone or together, or through one or more juridical person, has a controlling ownership interest or who exercises control through other means.

Explanation-

- a) “Controlling ownership interest” means ownership of or entitlement to more than twenty-five percent of shares or capital or profits of the company;
 - b) “Control” shall include the right to appoint majority of the directors or to control the management or policy decisions including by virtue of their shareholding or management rights or shareholder’s agreements or voting agreements.
- (ii) In case of a partnership firm, the beneficial owner is the natural person(s) who, whether acting alone or together, or through one or more juridical person, has ownership of entitlement to more than fifteen percent of capital or profits of the partnership;
 - (iii) In case of an unincorporated association or body of individuals, the beneficial owner is the natural person(s) who, whether acting alone or together, or through one or more

juridical person, has ownership of or entitlement to more than fifteen percent of the property or capital or profits of such association or body of individuals.

- (iv) Where no natural person is identified under (1) or (2) or (3) above, the beneficial owner is the relevant natural person who holds the position of senior managing official;
 - (v) In case of a trust, the identification of beneficial owner(s) shall include identification of the author of the trust, the trustee, the beneficiaries with fifteen percent or more interest in the trust and any other natural person exercising ultimate effective control over the trust through a chain of control or ownership.
- (e) An agent is a person employed to do any act for another, or to represent another in dealings with third person.
3. A bidder is permitted to procure raw material, components, sub-assemblies etc. from the vendors from countries which shares a land border with India. Such vendors will not be required to be registered with the Competent Authority, as it is not regarded as “sub-contracting”.
 4. However, in case a bidder has proposed to supply finished goods procured directly / indirectly from the vendors from the countries sharing land border with India, such vendor will be required to be registered with the Competent Authority.

Format of Certificate for Tenders for Works under Rule 144 (xi) in the General Financial Rules (GFRs), 2017

To
Head, CD
ECIL,
Hyderabad.

DECLARATION BY AUTHORISED SIGNATORY OF THE FIRM

Dear Sir,

Ref: Your Tender No. _____ dated _____
I/We, the undersigned, _____ (full name), do
hereby declare, in my capacity as _____ of
M/s. _____ (name of bidder entity), that:

1. I have read the Orders (Public Procurement No. 1,2&3) dt 23rd July 2020 & 24th July 2020 on the subject of Restrictions under Rule 144 (xi) of the General Financial Rule (GFRs), 2017 regarding restrictions on procurement from a bidder of a country which shares a land border with India.

2. I/we certify that M/s. _____ (name of bidder entity)

a) **is not from such a country.** I hereby certify that this bidder fulfils all requirements in this regard and is eligible to be considered. **OR,**

b) **is from such a country** (strike out whichever is not applicable), and has been registered with the Competent Authority. I hereby certify that this bidder fulfils all requirements in this regard and is eligible to be considered. [Where applicable, evidence of valid registration by the Competent Authority is attached)

3. I understand that the submission of incorrect data and / or if certificate / declaration given by M/s. _____ (name of bidder entity) is found to be false, this would be a ground for immediate termination and further legal action.

4. This declaration cum undertaking is executed by us through our Authorized signatory/ies after having read and understood the Office Memorandum and Order (Public Procurement No.1,2,3) dated 23rd and 24th July 2020 of Ministry of Finance, Department of Expenditure, Public Procurement Division, Government of India including the words defined in the said order which shall have the same meaning for the purpose of this Declaration cum Undertaking.

Executed at _____ On this the ____ day of _____

By Authorized Signatory
(Signature and Name)
Seal of the Bidder

*Note: Where applicable, evidence of valid registration by the Competent Authority shall be attached.